

6. Turnitin

by Iga Aju Nitya Dharmani

Submission date: 27-Sep-2022 10:57AM (UTC+0800)

Submission ID: 1910048184

File name: 6._Jurnal.pdf (455.32K)

Word count: 5181

Character count: 28260

The Influence of Product Quality, Brand Image and Promotion on The Purchase Decision of 3second Fashion

Rindi, Dr. Sengguruh Nilowardono, Agus Sukoco, IGA Aju Nitya Dharmani, Joko Suyono

Department of Management

Faculty of Economics and Business

Narotama University Surabaya, Indonesia

rindi@gmail.com, sengguruh@narotama.ac.id, agussukoco@narotama.ac.id,

aju.dharmani@narotama.ac.id, joko.suyono@narotama.ac.id

Abstract

This study aims to determine the effect of product quality, brand image and promotion on purchasing decisions of 3second Fashion Royal Plaza Surabaya fashion. A quantitative approach is used to answer the problems in this study, using 100 respondents. The analysis technique used is multiple linear regression analysis. The results show that, 1) Product quality influences purchasing decisions for the 3second Fashion Royal Plaza Surabaya fashion so that H1 is accepted. That is, the better the quality of the products sold, the higher the decision to buy the product. 2) Brand image influences purchasing decisions for 3second Fashion Royal Plaza Surabaya fashion so that H2 is accepted. That is, the better the brand image that is embedded in the minds of consumers, the decision to buy a product is increasing. 3) Promotion has an effect on purchasing decisions for 3second Fashion Royal Plaza Surabaya fashion so that H3 is accepted. That is, the more maximum promotional efforts made by the company, the decision to buy the product will increase. and 4) Product quality, brand image and promotion influence the purchasing decision of the 3second Fashion Royal Plaza Surabaya fashion so that H4 is accepted. That is, the existence of products with high quality, good brand image and maximum and well-targeted promotions will have an impact on increasing consumer purchasing decisions.

Keywords

Brand Image, Promotion, Purchase Decision, Product Quality

1. Introduction

Along with the development of an increasingly modern era, it has an impact on the shifting of cultural values from social society to become more individual. The density of business and high mobility of a person outside the home, causes people to prefer something practical and instant to be able to meet their needs. In addition, the rapid progress of science and technology also has an impact on the tight competition in the business world. Every company must be able to determine the right strategy to survive and expand its market share. Every business actor needs to study and understand the needs, wants and demands of each customer. Having this understanding will help design market offerings that are more desirable and build value burdens. Good relationships with customers will be beneficial for capturing customer lifetime value and a wider market share (Darmanto, & Wardana, 2016). Fulfillment of needs and wants will drive consumer purchasing decisions.

Purchasing decisions are a problem-solving process in an effort to meet consumer needs (Rossanty, Y., Nasution, Muhammad D. T. P., & Ario, 2018). Product purchase decisions are more defined as the process by which consumers make decisions to actually buy the product. Purchase decisions are influenced by several factors. So companies are required to always compete and attract the attention of consumers. There are several factors that can influence purchasing decisions, including product quality, brand image and promotion (Brata, B. H., Husani, S., & Ali, 2017).

The first factor is product quality. Product quality is an understanding that the products offered have advantages as expected by consumers (Firmansyah, 2019). The second factor is brand image. Brand image or brand image is the name, term, symbol, sign and design used by the company to distinguish it from competing products (Firmansyah, 2019). The third factor is promotion. According to Musfar, (2019), promotion as a component of marketing is considered very important in increasing brand recognition and also sales.

Research related to product quality, brand image and promotion of purchasing decisions has been carried out by several previous researchers. One of them is the research conducted by (Widjaja, Y. R., & Rahmat, 2017), which obtained the results that product quality has a positive and significant influence on consumer purchasing decisions. This means that the better the quality of a product, the purchasing decisions will increase. Contrary to research conducted by (Rumondor, P., Tumbel, A., & Ogi, 2017), which obtained the results that

4 product quality was not proven to have a significant effect on purchasing decisions. This means that the good or bad quality of a product does not guarantee that purchasing decisions will increase. Empirical studies were also conducted by (Evita, 2017), which obtained the results that brand image has a positive and significant influence on purchasing decisions. This means that with a positive brand image embedded in the minds of consumers, the purchase decision has increased. This is in contrast to the research conducted by (Wicaksono, D. A., Sumarsono, H., & Santoso, 2019), which found that brand image was not proven to have an effect on purchasing decisions. 4 search was also carried out by (Brata, B. H., Husani, S., & Ali, 2017), which showed that promotions proved to have a positive and significant effect on purchasing decisions. This means that with the right promotional strategy, it will help improve consumer purchasing decisions. Contrary to research conducted by (Rahmawati, Y., & Nilowardono, 2018), which proves that sales promotion does not have a significant contribution to purchasing decisions.

This research was conducted at the 3second Fashion Royal Plaza Surabaya fashion. 3Secend is one of the well-known clothing brands that is inherent among young people, with its center in Bandung, West Java. The quality of 3second Fashion products has a trendy and stylish concept, which is made with comfortable materials and not too flashy colors. Products from 3second Fashion also play more with fonts, with simple and unique designs so that they can become a special attraction for consumers. On the other hand, there are some people who think that 3second Fashion products are expensive, where a t-shirt with a simple design is sold for a minimum price of IDR 160,000. However, with the value in 3second Fashion products, there are still many people, especially young people who are still loyal to buying 3second Fashion products (Nadiya, F. H., & Wahyuningsih, 2020).

The brand image attached to 3second Fashion products is already embedded in the minds of consumers, especially among young people. The company uses celebrity endorsers to help introduce 3second Fashion products to the public, including Ariel "Noah", Raffi Ahmad and also Momo "Geisha". The products offered by 3second Fashion are not only t-shirts, there are also variations of other products such as jackets, shirts, pants, sweaters, hats, bags, belts, sandals and shoes. With an age of more than 15 years, 3second Fashion also cooperates with other brands, with the same company ownership, such as the Famo, Moutley and Greenlight brands. In an effort to increase sales and introduce products, 3second Fashion carries out various promotions, such as advertising on print media and social media. The company also provides exhibitions at certain events, besides that the company also provides attractive price discounts. Discount prices given by 3second Fashion such as buying 1 20% discount, buying 2 30% discount and buying 3 50% discount. Some 3second Fashion items also offer discounts of up to 50% (<https://3second Fashion.co.id/> accessed 24 April 2021).

12 2. Literature Review

2.1 Product Quality

Product quality is an understanding that the product offered has advantages as expected by consumers. In addition, product quality is also a public perception where the products offered by a company have advantages over competing products. So that the company will try to maintain the quality of the products it offers and compare with the products offered by competing companies (Firmansyah, 2019). According to Sunarto, (2015), product quality is the ability or characteristic possessed by a product, either goods or services, in meeting and satisfying consumer needs. If the product can carry out its functions, it can be said that the product has good quality. Based on a study conducted by (Brata, B. H., Husani, S., & Ali, 2017), quality products and in accordance with consumer expectations, the decision to purchase these products will be higher. Quality products, will encourage consumers to make purchases to meet their needs, otherwise if the product does not have quality, consumers will choose other alternatives to meet their needs. Related to this, the research hypothesis can be formulated as follows:

H₁: Product quality has a significant effect on purchasing decisions.

2.2 Brand Image

Brand image or brand image is the name, term, symbol, sign and design used by the company to distinguish it from competing products (Firmansyah, 2019). Image can be built with all media owned by the company, and is sustainable and has a message conveyed either through visual media, symbols, atmosphere or events. Basically, brand image is a consumer's perception of a particular brand based on considerations and comparisons made with several other brands of the same type. So that the brand image becomes an important element for the company in carrying out its marketing activities. Brand image also has the meaning of trust, where the existence of a brand image shows that consumers think that 11 certain brands are physically different from competing brands (Evita, 2017). According to Yudhanto, (2018), brand image is a set of 1 assumptions that exist in the minds of customers or consumers of a brand that arises from the existence of information and experience. The 1 image of a brand is related to customer attitudes in the form of beliefs and preferences for a particular brand. Brand image refers more to the customer's memory scheme of a brand, which contains customer interpretations related to attributes, uses, advantages, situations, users and marketer characteristics.

Based on a study conducted by (Ardiantika, D. B. C., & Rachmi, 2017) and shows that brand image has a significant influence on purchasing decisions. The existence of a positive perception in the minds of consumers regarding a brand, will be taken into consideration in decision making. A good brand image will make consumers more interested in having the product as a fulfillment of needs. Related to this, the research hypothesis can be formulated as follows:

H₂: Brand image has a significant effect on purchasing decisions.

2.3 Promotion

According to (Musfar, 2019), promotion as a component of marketing is considered very important in increasing brand recognition and also sales. The function of promotional activities is to achieve various communication goals with consumers. Promotion is the flow of information created by the company to be able to direct a person or organization to act by creating exchanges within the company. Based on the opinion of (Rinnanik, Priyanti, E., Buchori, Sulastri, S., Dede, Mardiono, T., 2021), promotion is defined as an activity designed by the company specifically in informing consumers about products and services so that they can be recognized and persuade consumers to buy these products and services. Promotional activities are not only a means of communication between companies and consumers, but also as suggestions in influencing consumers to buy or use services to meet their needs. Based on a study conducted by (Faizani, R. D., & Prihatini, 2020) shows that promotion has a significant influence on purchasing decisions. This means that promotions that are carried out properly will increase consumer knowledge of a product. So that if a need arises, consumers will always remember the product for the information conveyed through promotional activities. Related to this, the research hypothesis can be formulated as follows:

H₃: Promotion has a significant effect on purchasing decisions.

2.4 Purchase Decision

Purchasing decisions are the selection of two or more alternative choices that consumers can buy, where consumers will decide what to buy according to the significance value of the purchase (Miauw, 2016). In this case, consumer decisions can also be interpreted as a way for consumers to decide what to buy according to their needs. Purchasing decisions are problem-solving activities that individuals can do in selecting behavioral alternatives that are considered appropriate from two or more behavioral alternatives and are assessed as the most appropriate or appropriate actions by going through the decision-making stages (Firmansyah, 2019). The consumer's decision-making process is an important activity, because the process can contain various steps that occur before making a decision. Based on a study conducted by (Limpo, L., Rahim, A., & Hamzah, 2018), consumer purchasing decisions can be influenced by several factors, including product quality, price and promotion. This means that with good product quality, prices that are in accordance with the benefits provided from the product and the right promotion will be considered by consumers in the decision-making process. Another study conducted by (Wicaksono, D. A., Sumarsono, H., & Santoso, 2019), where brand image, product quality and product design are factors that can influence consumer purchasing decisions. Related to this, the research hypothesis can be formulated as follows:

H₄: Product quality, brand image, and promotion has a significant effect on purchasing decisions.

The framework of thinking in this research is as follows:

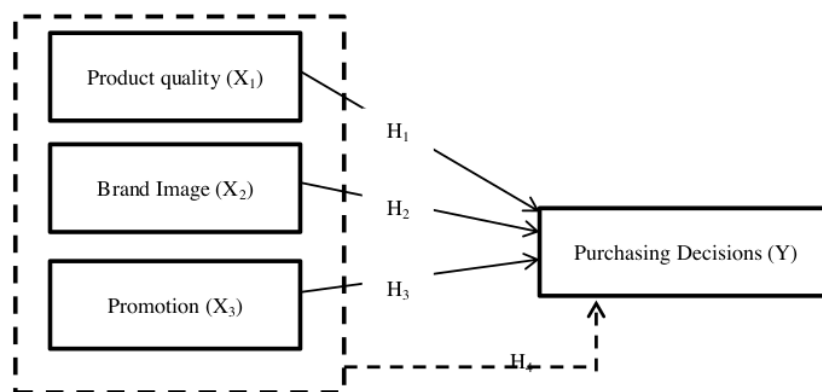

Figure 1. Framework of thinking

3. Methodology

A quantitative approach is used to answer the problem in this study. The object of this research is the 3second Fashion Royal Plaza Surabaya fashion consumer. The sampling technique in this study is incidental sampling, with the number of samples analyzed amounting to 100 respondents. Collecting data in this study in the form of a questionnaire or questionnaire. The data analysis technique used is multiple linear regression analysis, with partial hypothesis testing and simultaneous testing with the help of the SPSS version 25 program.

4. Results And Disuccion

4.1 Classic Assumption Test

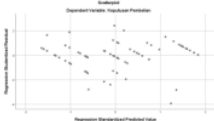
Classic Assumption Test	Results	Criteria	Description
Normality Test	0,091	Sig. > 0,05	Normal distributed data
Linierity Test			
Product quaity (X ₁)	Sig. = 0,000	36	Linier date
Brand image (X ₂)	Sig. = 0,000	Sig. < 0,05	
Promotion (X ₃)	Sig. = 0,000		
Multikolinierity Test	Tolerance VIF		
Product quaity (X ₁)	0,614 1,628	Tolerance > 0,1	Free of multicollinearity Free of multicollinearity
Brand image (X ₂)	0,389 1,470	VIF < 10	
Promotion (X ₃)	0,440 1,274		
Heteroskedastisity Test			Free of heteroscedasticity
Autocorrelation Test	1,963	between -2 to 2	Free of autocorrelation

4.2 Multiple Linear Regression Analysis

Table 2 Multiple Linear Regression Analysis Test Results Coefficients^a

Model		Unstandardized Coefficients		Standardized Coefficients
		B	Std. Error	Beta
1	(Constant)	4.013	.969	
	Product quality (X ₁)	.141	.056	.148
	Brand image (X ₂)	.593	.071	.615
	Promotion (X ₃)	.237	.075	.221

a. Dependent Variable: Purchase decision

Based on the table above, the following equation is obtained:

$$Y = 4,013 + 0,141 X_1 + 0,593 X_2 + 0,237 X_3 + e$$

The following is an explanation of the obtained equation:

1. The constant value is 4.013. That is, without the influence of the independent variables, namely product quality, brand image and promotion, the value of the purchasing decision variable remains constant at 4.013.
2. The coefficient value of the product quality variable is 0.141 with a positive value. This means that every increase of one unit of product quality variable will have an impact on an increase in the purchasing decision variable of 0.141 with the assumption that other factors are constant or fixed.
3. The coefficient value of the brand image variable is 0.593 with a positive value. This means that every one unit increase in the brand image variable will have an impact on the increase in the purchasing decision variable by 0.593 with the assumption that other factors are constant or fixed.
4. The coefficient value of the promotion variable is 0.237 with a positive value. This means that every increase in one unit of the promotion variable will have an impact on the increase in the purchasing decision variable of 0.237 with the assumption that other factors are constant or fixed.

4.3 Hypothesis Test

Tabel 3 Hypothesis Test Results

Model	T _{count}	Sig.	F _{count}	Sig.	R	R Square
1 (Constant)	4.140	.000	123.874	.000 ^b	.891 ^a	.795
Product quality (X1)	2.502	.014				
Brand image (X2)	8.290	.000				
Promotion (X3)	3.169	.002				

a. Dependent Variable: Purchase decision

Based on the table above, it can be explained as follows:

1. The product quality variable obtained a value of tcount = 2.502 with a significance of 0.014 <0.05. This means that the product quality variable partially affects the purchasing decision variables.
2. Brand image variable obtained tcount = 8,290 with a significance of 0.000 <0.05. This means that the brand image variable partially influences the purchasing decision variable.
3. Promotion variable obtained tcount = 3.169 with a significance of 0.003 <0.05. This means that the promotion variable partially influences the purchasing decision variable.

Based on the table above, it is known that the F value obtained is 123.874 with a significance of 0.000 < 0.05. This means that the variables of product quality, brand image and promotion simultaneously affect the purchasing decision variables. The R value is 0.891 or 89.1%. This means that the ups and downs of the purchasing decision variables are influenced by the product quality, brand image and promotion variables of 89.1%; while the rest are influenced by other variables outside the study. The R Square value is 0.795 or 79.5%. This means that the ups and downs of the dependent variable, namely purchasing decisions can be explained by product quality, brand image and promotion variables of 79.5% while the rest can be explained by other variables outside the study.

4.4 Discussion

1. Product Quality Affects the Purchase Decision of Fasion 3second Fashion Royal Plaza Surabaya

H₁ : Product quality has a significant effect on purchasing decisions. Data analysis proves that product quality influences purchasing decisions for 3second Fashion Royal Plaza Surabaya fashion so that H1 is accepted. That is, the better the quality of the products sold, the higher the decision to buy the product. According to (Untari, 2019), product quality is an understanding of the products offered by manufacturers and sellers that have more selling value that competing products do not have, so companies are required to focus on product quality and compare them with competing products. The existence of product quality, makes the product chosen by the public to be purchased and consumed. If the product can carry out its functions, it can be said that the product has good quality. Products that have quality, will be a consideration for consumers to buy and consume them. Research conducted by (Brata, B. H., Husani, S., & Ali, 2017) shows that product quality influences purchasing decisions. This shows that the better the value of the product used by consumers compared to the sacrifices used to obtain the product, it will encourage consumers to make a purchase. Similar research was also conducted by (Rahmawati, Y., & Nilowardono, 2018) and showed that product quality had a significant effect on purchasing decisions.

2. Brand Image Affects the Purchase Decision of Fasion 3second Fashion Royal Plaza Surabaya

H₂ : Brand image has a significant effect on purchasing decisions. Data analysis proves that brand image influences purchasing decisions for 3second Fashion Royal Plaza Surabaya fashion so that H2 is accepted. That is, the better the brand image that is embedded in the minds of consumers, the decision to buy a product is increasing. Brand image or brand image is the name, term, symbol, sign and design used by the company to distinguish it from competing products (Firmansyah, 2019). Basically, brand image is a consumer's perception of a particular brand based on considerations and comparisons made with several other brands of the same type. So that the brand image becomes an important element for the company in carrying out its marketing activities. Brand image can be built with all media owned by the company, and is sustainable and has a message conveyed either through visual media, symbols, atmosphere or events. The existence of a different and unique brand image becomes the most important thing, because the product is increasingly complex and the market is wider, so consumers will be more dependent on the brand image compared to the actual brand attributes. In a study conducted by (Evita, 2017) showed that brand image has a significant influence on purchasing decisions. This shows that the better the brand image that is embedded in the minds of consumers, the purchasing decisions will increase. Research with similar results was also conducted by (Ardiantika, D. B. C., & Rachmi, 2017) and shows that brand image has a significant influence on purchasing decisions.

3. Promotion Affects the Purchase Decision of Fasion 3second Fashion Royal Plaza Surabaya

H₃ : Promotion has a significant effect on purchasing decisions. Data analysis proves that promotion has an effect on purchasing decisions for 3second Fashion Royal Plaza Surabaya fashion so that H3 is accepted. That is, the more maximum promotional efforts made by the company, the decision to buy the product will

increase. According to (Musfar, 2019), promotion as a component of marketing is considered very important in increasing brand recognition and also sales. The function of promotional activities is to achieve various communication goals with consumers. Through sales promotion, companies can attract new customers, influence their customers to try new products, encourage customers to buy more, attack competitors' promotional activities, increase impulse buying (purchases without prior plans), or seek closer cooperation with retailers. In a study conducted by (Faizani, R. D., & Prihatini, 2020) showed that promotion has a significant influence on purchasing decisions. Sales promotion is a form of marketing communication that seeks to disseminate information, influence or persuade and remind the target market of the company and its products, to buy and be loyal to the products offered.

4. Product Quality, Brand Image and Promotion Affect the Purchase Decision of Fasion 3second Fashion Royal Plaza Surabaya ³⁰

H₄ : Product quality, brand image and promotion have a significant effect on purchasing decisions. Data analysis proves that product quality, brand image and promotion influence the purchasing decision of the 3second Fashion Royal Plaza Surabaya fashion so that H₄ is accepted. That is, the existence of products with high quality, good brand image a²¹ maximum and well-targeted promotions will have an impact on increasing consumer purchasing decisions. From the results of the correlation coefficient test, the R value of 0.891 or 89.1% was obtained. This means that the ups and downs of the purchasing decision variables are influenced by the product quality, brand image ¹⁹ promotion variables of 89.1%; while the rest are influenced by other variables outside the study. While the results of the coefficient of determination test show that the R Square value is 0.795 or 79.5%. This means that the ups and downs of the dependent variable, namely purchasing decisions can be explained by product quality, brand image and promotion variables of 79.5% while the rest can be explained by other variables outside the study.

5. Conclusion

The following are the conclusions in this study:

1. The quality of the product influences the purchasing decision of the 3second Fashion Royal Plaza Surabaya fasion so that H₁ is accepted. That is, the better the quality of the products sold, the higher the decision to buy the product.
2. Brand image influences purchasing decisions for 3second Fashion Royal Plaza Surabaya fashion so that H₂ is accepted. That is, the better the brand image that is embedded in the minds of consumers, the decision to buy a product is increasing.
3. Promotion has an effect on purchasing decisions for 3second Fashion Royal Plaza Surabaya fashion so that H₃ is accepted. That is, the more maximum promotional efforts made by the company, the decision to buy the product will increase.
4. Product quality, brand image and promotion influence the purchasing decision of the 3second Fashion Royal Plaza Surabaya fashion so that H₄ is accepted. That is, the existence of products with high quality, good brand image and maximum and well-targeted promotions will have an impact on increasing consumer purchasing decisions.

The following suggestions are put forward regarding the research findings:

5. The 3second Fashion Royal Plaza Surabaya party maximizes promotional activities, for example by promoting through their social media.
6. For further research can add other variables such as price. This is because according to the results of the study there are other variables that influence purchasing decisions.

References

- ⁷ Ardiantika, D. B. C., & Rachmi, A. (2017). Pengaruh Inovasi Produk dan Brand Image Terhadap Keputusan Pembelian Pada Olivia Cake And Bakery Mojokerto. *Jurnal Aplikasi Bisnis*, 3(1), 86–91.
- Brata, B. H., Husani, S., & Ali, H. (2017). The Influence of Quality Products, Price, Promotion, and Location to Product Purchase Decision on Nitchi At PT. Jaya Swarasa Agung in Central Jakarta. *Saudi Journal of Business and Management Studies*, 2(4b), 433–445.
- Darmanto, & Wardana, S. (2016). *Manajemen Pemasaran Untuk Mahasiswa, Usaha Mikro, Kecil dan Menengah* (Deepublish (ed.)).
- Evita, N. (2017). Pengaruh Citra Merek Terhadap Keputusan Pembelian (Studi Kasus Pada Bakso Boedjangan ¹⁰ Cabang Burangrang Bandung Tahun 2017). *Proceeding of Applied Science*, 3(2), 430–452.
- Faizani, R. D., & Prihatini, A. E. (2020). Pengaruh Promosi dan Harga Terhadap Keputusan Pembelian Baju ²² Merek the Executive PT Delami Garment Industries. *Jurnal Ilmu Administrasi Bisnis*.
- Firmansyah, M. A. (2019). *Pemasaran Produk dan Merek (Planning dan Strategy)*. Qiara Media.

- 9 Limpo, L., Rahim, A., & Hamzah, H. (2018). Effect of Product Quality, Price, and Promotion to Purchase Decision. *International Journal on Advanced Science, Education, and Religion*.
8 <https://doi.org/https://doi.org/10.33648/ijoaser.v1i1.2>
- 16 Miauw, K. Y. H. (2016). Motivasi Konsumen Dan Sikap Konsumen Terhadap Keputusan Pembelian Di Wild. *Jurnal Manajemen Dan Start-Up Bisnis*, 1(5), 1–9.
- Musfar, T. F. (2019). *Buku Ajar Manajemen Pemasaran Bauran Pemasaran sebagai Materi Pokok dalam Manajemen Pemasaran* (PT Elex Media Komputindo (ed.)).
- Nadiya, F. H., & Wahyuningsih, S. (2020). Pengaruh Kualitas Produk, Harga dan Citra Merek Terhadap Keputusan Pembelian Fashion 3second Fashion Di Marketplace (Studi Pada Mahasiswa Pengguna Fashion 3second Fashion Di Kota Semarang). *Jurnal Ilmu Dan Riset Manajemen*, 5(2), 1–20.
- Rahmawati, Y., & Nilowardono, S. (2018). The Effect of Product Quality, Brand Trust, Price and Sales Promotion on Purchase Decisions on Royal Residence Surabaya (Case Study in PT. Propnex Revisit). *IJIEEB: International Journal of Integrated Education, Engineering and Business*, 1(1), 1–10.
<https://doi.org/https://doi.org/10.29138/ijieeb.v1i1.792>
- Rinnanik, Priyanti, E., Buchori, Sulastri, S., Dede, Mardiono, T., ... Misubargo. (2021). *Ilmu Manajemen di Era 4.0*. (CV Adanu Abimata (ed.)).
- Rossanty, Y., Nasution, Muhammad D. T. P., & Ario, Firman. (2018). *Cunsumer Behavior In Era Millennial* (L. P. dan P. I. Aqli (ed.)).
- Rumondor, P., Tumbel, A., & Ogi, I. (2017). Pengaruh Kualitas Produk, Harga, dan Word Of Mouth Terhadap Keputusan Pembelian Pada Rumah Kopi Dan Mie Toronata Di Kawangkoan. *Jurnal Riset Ekonomi, Manajemen, Bisnis Dan Akuntansi*, 5(2), 1102–1112.
<https://doi.org/https://doi.org/10.35794/emba.v5i2.16084>
- Sunarto, S. (2015). Pengaruh Kualitas Produk Terhadap Keputusan Pembelian Pada Toko Kulit Kartika Magetan. *EQUILIBRIUM: Jurnal Ilmiah Ekonomi Dan Pembelajarannya*, 3(2), 191–205.
20 <https://doi.org/https://doi.org/10.25273/equilibrium.v3i2.668>
- Untari, D. T. (2019). *Manajemen Pemasaran: Kasus Dalam Pengembangan Pasar Wisata Kuliner Tradisional betawi* (C. P. P. Redaksi (ed.)).
- Wicaksono, D. A., Sumarsono, H., & Santoso, A. (2019). Pengaruh Citra Merek (Brand Image), Kualitas Produk, dan Desain Produk Terhadap Keputusan Pembelian Pada Produk Batik Mukti. *ISOQUANT: Jurnal Ekonomi, Manajemen Dan Akuntansi*, 3(4), 81–89. <https://doi.org/https://doi.org/10.24269/iso.v3i1.242>
- Widjaja, Y. R., & Rahmat, F. D. J. v. (2017). Pengaruh Kualitas Produk dan Harga terhadap Keputusan Pembelian di Rumh Makan Kampoeng Sawah Kabupaten Bandung. *Ekspansi*, 9(1), 71–95.
- Yudhanto, Y. (2018). *Information Technology Business Start-Up* (PT Elex Media Komputindo (ed.)).

Biography / Biographies

Rindi is a student of Narotama University, Surabaya, Indonesia, majoring in Marketing Management, Departement of Management, Faculty of Economic and Business.

Sengguruh Nilowardono is a permanent lecturer at the Faculty of Economics and Business, Narotama University, Surabaya. Completed his Doctoral education in Management Science at the Postgraduate School of the Widya Mandala Catholic University, Surabaya. Previously served as Head of Narotama University's Master of Management Study Program and Head of Narotama University's Career Center. Some of his journal publications have been indexed by Scopus. Some of the subjects taught include Brand Management, Digital Marketing, Strategic Marketing Management, Marketing Research, Marketing Practicum, Consumer Behavior. In addition, he is a BNSP Assessor certification holder for the field of Marketing Management.

Agus Sukoco is a Lecturer/Revisior of the Faculty of Economics and Business, Narotama University, Surabaya, Indonesia. He holds a Bachelor's degree in Naval Architecture and Shipbuilding Engineering from the Sepuluh Nopember Institute of Technology, a Master's degree in Business Management at Narotama University and a Doctoral Degree in Business Management Student at STESIA, Indonesia. He has been recognized as a professional construction management consultant with over 18 years of experience working with closely held businesses. He is also a member of INTAKINDO Consultant Indonesia.

IGA Aju Nitya Dharmani, fondly called Bu Ayu Rai, is a permanent lecturer at the Faculty of Economics and Business, Narotama University, Surabaya. This multi-talented lecturer as a Permanent Lecturer of FEB Management Study Program at Univ Narotama has served as Head of Study Program. Publication of Introduction to Business Textbooks with ISBNs and registered at the National Library of Indonesia. His journal publications have been indexed by Scopus. Some of the courses taught include Introduction to Business, Introduction to Management, Business Ethics.

Community activities are also supervised as CHAIRMAN OF HIPWA (Shop Traders Association) JAWATIMUR, Secretary of PERSANI (Indonesian Gymnastics Athlete Association) Surabaya City, Head of KPJ (East Java Perias Community), Pembina DPW PEKNAS East Java. Strengthening the National People's Economy (PEKNAS) Also as a ludruk artist for the Sinar Nusantara Cultural Rhythm.

Joko suyono is a lecturer at Narotama University, Surabaya, Indonesia. He is also as Head of Master of management at Narotama University, Surabaya, Indonesi. He got bachelor degree in business administration and also accounting, he got master degree in industrial management and also in marketing management, andhe got doctoral degree in business administration. Prior becoming a lecturer, he is a practitioner as senior manager in some multional corporation such as Stanley Works Indonsia (USA Company), ericsson Indonesia (Europea Company) and lotus Indah Textile Industries, a multinational company in the textile, spun yarns.

6. Turnitin

ORIGINALITY REPORT

12%

SIMILARITY INDEX

9%

INTERNET SOURCES

4%

PUBLICATIONS

6%

STUDENT PAPERS

PRIMARY SOURCES

1	Submitted to Universitas 17 Agustus 1945 Surabaya Student Paper	1%
2	Submitted to Universitas Wijaya Kusuma Surabaya Student Paper	1%
3	Submitted to Forum Perpustakaan Perguruan Tinggi Indonesia Jawa Timur Student Paper	1%
4	eproceeding.undwi.ac.id Internet Source	1%
5	Submitted to Universitas Nasional Student Paper	1%
6	www.growingscience.com Internet Source	1%
7	ojs.uma.ac.id Internet Source	1%
8	Submitted to Fakultas Ekonomi, Bisnis dan Pariwisata Student Paper	<1%

9	repository.uib.ac.id Internet Source	<1 %
10	ejournal3.undip.ac.id Internet Source	<1 %
11	Catur Rachmad Susetyo, Sengguruh Nilowardono, Ani Wulandari. "Effect of Brand Identity and Brand Image On Customer Loyalty Case Study In Daihatsu Car Consumer", Quantitative Economics and Management Studies, 2020 Publication	<1 %
12	media.neliti.com Internet Source	<1 %
13	ejurnal-mapalus-unima.ac.id Internet Source	<1 %
14	ejurnal.provisi.ac.id Internet Source	<1 %
15	Submitted to UM Surabaya Student Paper	<1 %
16	repository.uph.edu Internet Source	<1 %
17	braemarsa.com Internet Source	<1 %
18	Lim Sanny, Michael Gerardo. "ANALYSIS OF PRIVACY PERCEPTIONS THROUGH SHOPPING	<1 %

BEHAVIOR IN INDONESIAN E-COMMERCE",
Humanities & Social Sciences Reviews, 2020

Publication

19 uia.e-journal.id <1 %
Internet Source

20 Submitted to Binus University International <1 %
Student Paper

21 jurnal.syntaxtransformation.co.id <1 %
Internet Source

22 pub.unj.ac.id <1 %
Internet Source

23 ejournal.bsi.ac.id <1 %
Internet Source

24 Hansen Kant Wee Han, Novera Kristianti Maharani. "The Effect of Utilization of Accounting Information Systems and Quality of Human Resources on the Quality of Financial Reports", Al Qalam: Jurnal Ilmiah Keagamaan dan Kemasyarakatan, 2022 <1 %
Publication

25 ebgc.upnjatim.ac.id <1 %
Internet Source

26 journal.ipm2kpe.or.id <1 %
Internet Source

27 Meihong Zhu, Aihua Li. "Media guiding effects on public perceptions of the Chinese" <1 %

government anticorruption: evidence from a survey experiment", Procedia Computer Science, 2017

Publication

28

conference.upnvj.ac.id

Internet Source

<1 %

29

ejournal.forda-mof.org

Internet Source

<1 %

30

jiemar.org

Internet Source

<1 %

31

journal.iaimnumetrolampung.ac.id

Internet Source

<1 %

32

www.unud.ac.id

Internet Source

<1 %

33

Grisna Anggadwita, Erni Martini, Ratih Hendayani, Muhammad Rafi Kamil. "The Role of Technology and Innovation Capabilities in Achieving Business Resilience of MSMEs During Covid-19: Empirical Study", 2021 9th International Conference on Information and Communication Technology (ICoICT), 2021

Publication

<1 %

34

journal.feb.unmul.ac.id

Internet Source

<1 %

35

journal.lppmunindra.ac.id

Internet Source

<1 %

36

jurnalmahasiswa.unipasby.ac.id

Internet Source

<1 %

37

ojs.unud.ac.id

Internet Source

<1 %

38

repository.unair.ac.id

Internet Source

<1 %

Exclude quotes Off

Exclude matches Off

Exclude bibliography Off

6. Turnitin

GRADEMARK REPORT

FINAL GRADE

/0

GENERAL COMMENTS

Instructor

PAGE 1

PAGE 2

PAGE 3

PAGE 4

PAGE 5

PAGE 6

PAGE 7

PAGE 8
